

Installation & Operation Instructions

HeatPumpPro® Zone Control Panel

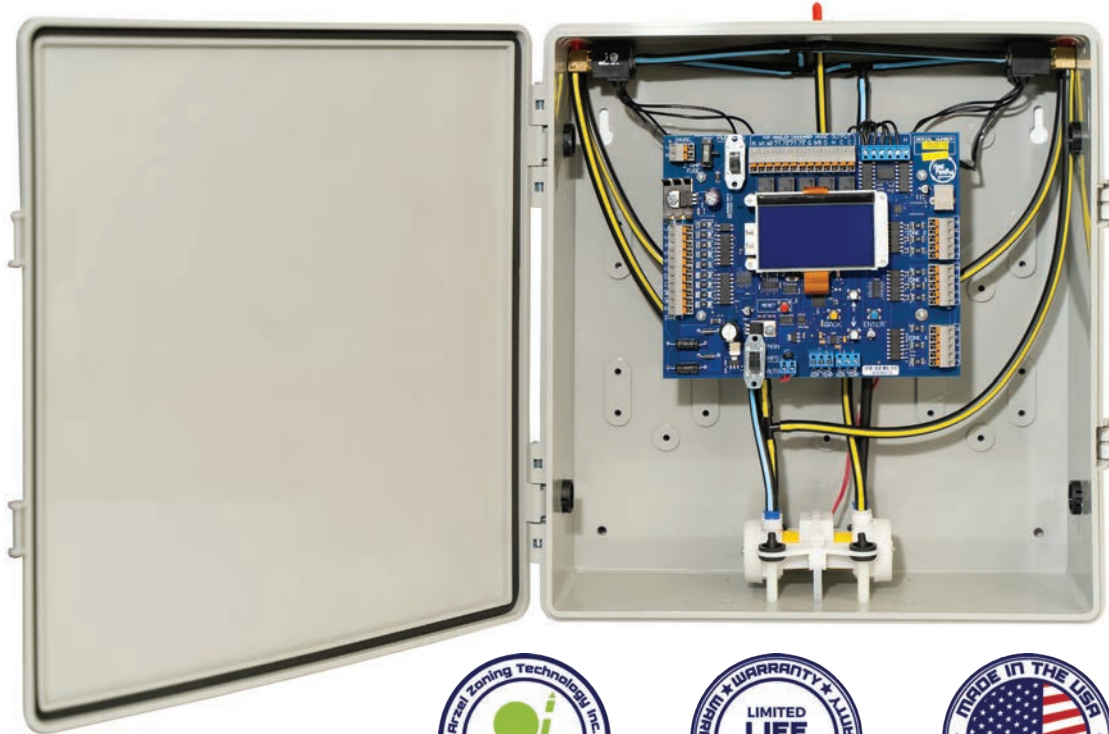

 **Arzel Zoning**
TECHNOLOGY

Arzel Zoning Technology, Inc.
4801 Commerce Pkwy.
Cleveland, OH 44128

Ph: (216) 831-6068
Fax: (216) 831-6074

www.arzelzoning.com

TECH SUPPORT

Call toll-free (800) 611-8312
Monday - Sunday, 8am-9pm EST
techsupport@arzelzoning.com

©2024 Arzel Zoning Technology

Table of Contents

Topic	Page
Operating your new zoning system.....	3
Product overview	4
Installation precautions.....	5
Board layout	6
Installation and setup instructions.....	7
Wiring diagrams.....	8
LAT and OAT sensor installation	10
Zone weight calculation.....	11
Leaving air temperature (LAT) controls	12
Pump operation.....	13
LCD display description	14
Sequence of operation	15
Setup wizard.....	17
Suggested settings.....	21
System commissioning	23
Remote emergency heat switch	24
Setup worksheet	25
Bypass chart	26
EzySlide® damper installation	27
Warranty information and procedure	28

Thank you for choosing Arzel!

Thank you for choosing the Arzel® HeatPumPro® zoning system for your comfort and energy efficiency needs. The HeatPumPro represents the latest in zoning technology. It is designed to both enhance your system's performance and deliver just the right amount of heating and cooling to every area of your home or building.

Please be assured that in addition to having the highest in product quality, we are committed to unparalleled product performance and complete customer satisfaction.



Operating your new zoning system

Your zoning system is simple to operate and requires no maintenance.

The system will allow you to increase your comfort by directing conditioned air to separate areas (zones) based upon each zones' thermostat setting. It provides the opportunity to conserve energy by adjusting the thermostat setting in unoccupied areas to energy saving levels.

To operate the system, just set or program each zones' thermostat to your desired comfort and/or setback settings. When there is a call for heating or cooling from any zone, the appropriate heating or cooling equipment will be turned on. The dampers in zones not requiring heating or cooling will close and the conditioned air will be directed to the calling zone(s) until the thermostat is satisfied.

The system responds to each thermostat on a first-call/ first-serve basis unless your contractor has programmed an alternate priority approach to deal with concurrent heat and cool calls with your application. The system can be set to an Automatic Priority (first-call/ first-serve), Heat Priority, Cool Priority or a Zone Weight Priority setting. Please refer to page 17 or consult your contractor for more details regarding the priority option programmed for your system.

When there is not an active call for heating or cooling, you may circulate air in individual zones by selecting the "Fan ON" function on each individual thermostat. The dampers in zones with the fan set to "Auto" will close.

Please feel free to learn more about the installation and operation of the Arzel® HeatPumPro® by reviewing this entire manual. Consult your installing contractor with any questions regarding system operation. If questions are still unresolved, you may call Arzel's Technical support for homeowners from 8 AM – 5 PM EST, Monday–Friday. Please have your system serial number available when you call. Your installing contractor can reach Arzel® Technical support 7 days a week, 8AM – 9 PM EST. The Arzel Technical support phone number is **1-800-611-8312**.

Product Overview

The HeatPumPro® is a non-proprietary, residential and light commercial zoning system, designed for heat pump or standard heat/cool control. Innovative features provide the opportunity to customize the control to meet the needs of any forced air system and maximize its efficiency and effectiveness.

Pro-Active Staging

The system will automatically “stage-up” to avoid the feeling of low supply air temperatures when the heat pump’s capacity is not sufficient to provide heated discharge air. The user will not have to wait for the temperature in the space to continue to fall before the equipment reacts. This feature also reduces or eliminates the need for two-stage thermostats by measuring outdoor air temperature and controlling the staging decision based on the calculated heating requirements.

Staging Based upon Zone Weight

The air handler or blower “stages” independently from the condenser Y1/Y2 and W1/W2 heating. Zone weight staging of the blower reduces or eliminates the need for a bypass by matching the W1/Y1 outputs to the available ductwork.

Broad Thermostat Compatibility

The HeatPumPro® is compatible with any conventional 24VAC thermostat including wireless, auto/manual changeover, programmable, non-programmable, WiFi, and home automation. Zone 1 will accept any heat/cool or heat pump thermostat. A heat pump thermostat can be used on Zone 1 to provide convenient control of emergency heat. Zones 2-4 must use standard four or five wire single-stage heat/cool thermostats only.

Humidification and Dehumidification

With the addition of a simple humidistat, the HeatPumPro® can control 24vac humidifiers when an active heating call is being served; a solenoid and damper can be added for controlling airflow through a bypass humidifier. It can also operate the system similar to a whole house humidifier. By adding a dehumidistat to zone 1, the panel will output for “G” to the blower and Y1 to the condenser for an adjustable period of time when no active calls are being served. The HVAC out “D” can be connected to the furnace 24vac, “DEHUM” terminal to active the furnaces dehumidification blower profile.

Additional Built-in Controls

- Full function Dual Fuel control
- Leaving Air Temperature settings (High/Low) provide equipment protection at reduced CFM operation and stage down capacity control.
- Outdoor Air Temperature sensor provides an outdoor reset function, balance point control, auxiliary resistant heat lock out and low ambient cooling lock out.

INSTALLATION PRECAUTIONS

Read these instructions carefully. Failure to follow them could damage the Arzel zoning system and/or cause a hazardous condition.

Warning

1. Disconnect the power supply to the HVAC system and the zoning system before making any wiring connections to prevent the danger of electrical shock or equipment damage.
2. Be sure the HVAC manufacturer's operating specifications are compatible with the Arzel zoning system.
3. All wiring must comply with applicable electrical codes, ordinances and regulations.
4. Use properly grounded tools, safety glasses and gloves when drilling or cutting sheet-metal ducts, fiberglass or any hard objects.

Caution

1. The Arzel system is designed for indoor use only.
2. You must touch a grounded metal object before handling the control panel to avoid potential loss of internal programs due to electrostatic discharge.
3. Install in ambient temperature between 40° F and 140° F in a non-condensing area.
4. Check all system operations after installation is complete.
5. The damper blade gently wipes the inside of the ductwork. Insert a sleeve inside any fiberglass, or abraidable ductwork, so the blade does not abrade the materials into the air.
6. Leave these instructions with the installed system for future use.
7. There are both AC and DC terminals on the circuit board. Do not intermingle wires.
8. The purpose of the LAT (Leaving Air Temperature) control is to function as an "operating limit" When set per the instructions it will add additional capacity control and prevent the equipment from operating outside the OEM's specifications.

General System Operation

A call from any zone thermostat will initiate HVAC equipment operation and position the solenoid air valve to open the damper(s) for its zone. The mini pump is energized to automatically activate the dampers, either open or closed, as required. Vacuum opens the dampers and pressure closes the dampers. When a call is satisfied, dampers are held in

place for 30 seconds after compressor only operations or two minutes after auxiliary or backup heat operations. This will allow the residual conditioned air to be delivered into last zone satisfied. The adjustable Secondary Purge Time (0 to 180 seconds) will continue to operate the pump to open all the zone dampers for a Soft Start™ on the next cycle.

Board Layout

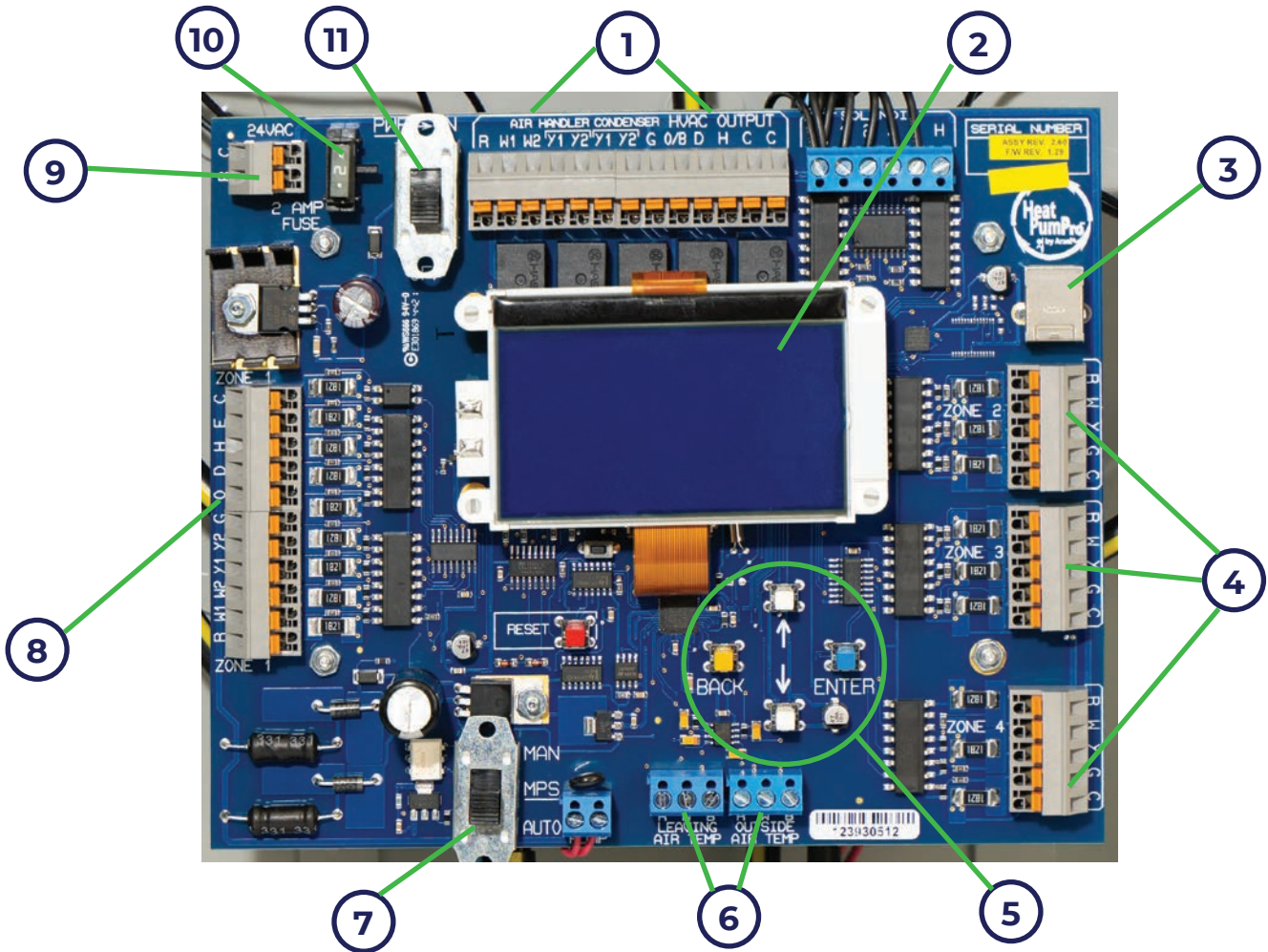

Item #	Description	Function
1	HVAC outputs	Dry contacts to control HVAC equipment
2	Lighted LCD display	Provides all system information at a glance and simplifies system setup using a guided setup wizard
3	USB port	Download operation history
4	Zone 2 through Zone 4 inputs	Four- or five-wire thermostat inputs (heat/cool thermostats only)
5	Navigation buttons	Provides programming interface for setup wizard
6	Sensor inputs	Connections for leaving air temperature (LAT) and outdoor air temperature (OAT) sensors. Both sensors MUST be installed for proper operation.
7	MPS switch	Auto/manual switch for the pump
8	Zone 1 input terminal	Inputs for any 24 VAC thermostat, heat pump or heat/cool
9	24 VAC power input	Arzel transformer connections "R" and "C" (40VA)
10	2 amp fuse	Protects the board against thermostat wiring shorts
11	Power switch	Controls 24 VAC power source to zone control panel

Installation and Setup Instructions

1. Install Dampers/Run Tubing

Dampers install directly into new or existing ductwork. Orient the tube connection port so it is pointing up-stream (toward the equipment). Install one main tubing run for each zone. Use connection “T’s” for multiple dampers in a zone. Arzel® recommends using a different color tube for each zone. **Dampers should not be concealed behind a permanent barrier such as drywall without an access panel.**

2. Mount Control Panel

The control panel must be mounted vertically on an exterior wall to reduce noise. The wall must also be located in a non-condensing area where temperatures will not normally exceed 140° F. **DO NOT MOUNT PANEL ON DUCTWORK, HVAC EQUIPMENT, STAIRWELL, or BEDROOM WALLS.** The best method is to attach a piece of ¾ plywood to an exterior stud wall or foundation. Hold the panel level on the wall and mark the positions of the upper mounting holes. Drive two screws into the wall leaving the heads at least ½” out. Set the panel over the screws. Drive two screws into the lower mounting holes. Tighten the upper screws. **Prior to making electrical connections, touch a mechanical ground to discharge static electricity.**

3. Connect Thermostats

Install a thermostat for each zone observing terminal designations. Use 18 AWG, multi-conductor, solid thermostat wire to connect thermostats to the control panel. **When using a heat pump thermostat at Zone 1, “O” must be energized on a call for cooling.** Zones 2, 3, 4 must be conventional Heat/Cool thermostats. Document the location of each thermostat connected to the zones on the “Zone Layout” label on the side of the panel.

4. Connect Equipment

Use 18 AWG, multi-conductor, solid thermostat wire to connect the HVAC outputs located along the top of the zone control panel to the HVAC equipment. Connect Y1, Y2 “Air Handler” to the blower or furnace controls and the Y1, Y2 “Condenser” to the heat pump/air conditioner controls. The two “C” terminals are for connection between the furnace/air handler transformer and the common circuit of the heat pump/air conditioner controls.

5. Connect Transformer

Use 18 AWG, 2-conductor solid wire to connect the R and C power input terminals to the mounting screws on the 40VAC self-resetting, plug-in transformer supplied with the Arzel® Zoning System. Plug in the transformer to any standard 120VAC receptacle. **If you do not use the provided transformer, your warranty may be void. Additional surge protection is recommended.**

6. Connect Sensors

- Install the leaving air temperature sensor in the supply duct 12 to 18 inches from the plenum and before any dampers.
- Install the Outdoor Air Temperature sensor outdoors, preferably on the north side of the house, not in direct sunlight.
- Wires must be connected to corresponding terminals, R-red, W-white and B-black.

7. Turn on Panel and Run the Setup Wizard

Wiring Diagrams

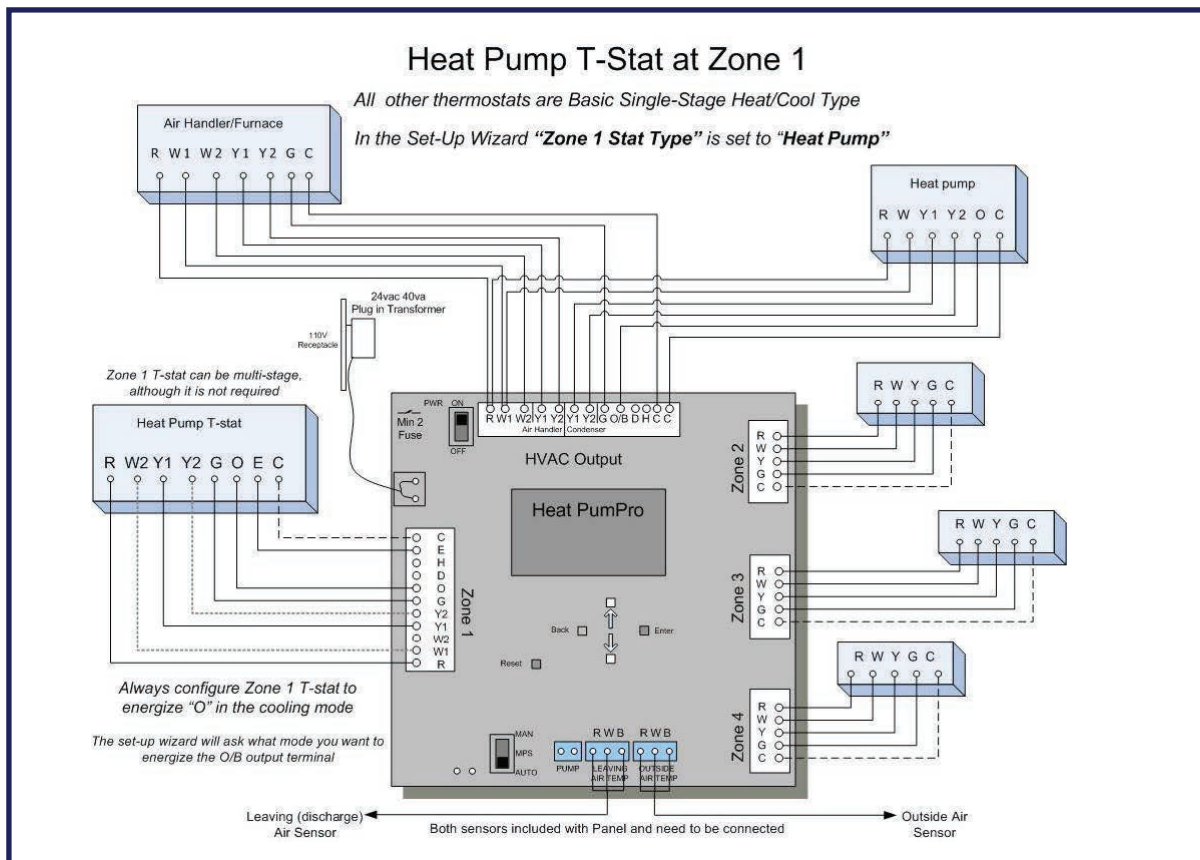
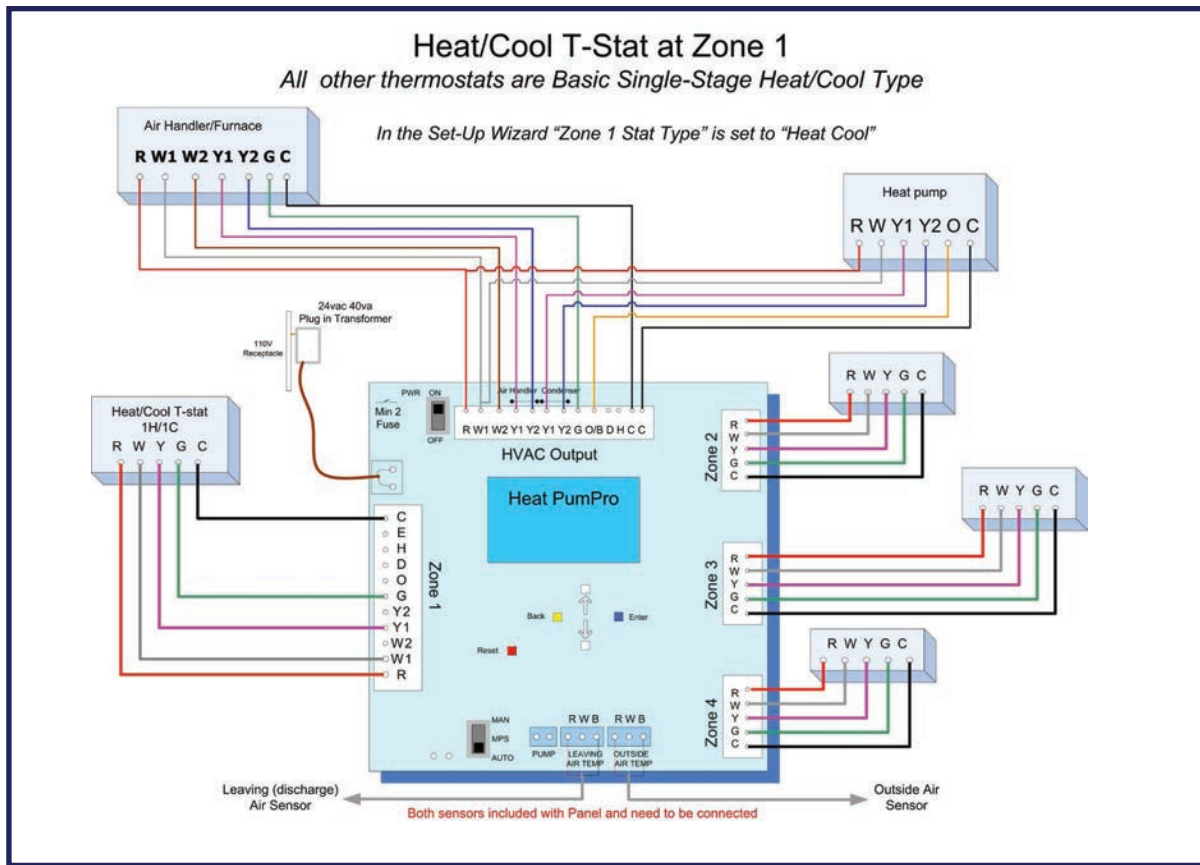

Wiring Diagrams

Humidity Control with Independent Humidistat & Dehumidistat

Zone 1 "H" terminal is normally at 0 vac and goes to "24" volts during a call for Humidification
 Zone 1 "D" terminal is normally at 0 vac and goes to "24" volts during a call for Dehumidification

In the "Set-Up Wizard", "Dehum Signal" must be set for "24 Volts"
 With out cooling calls, the Dehum cycle will cycle off every 5, 10 or 15 min according to the Set-Up wizard "Dehum Cycle Time" setting

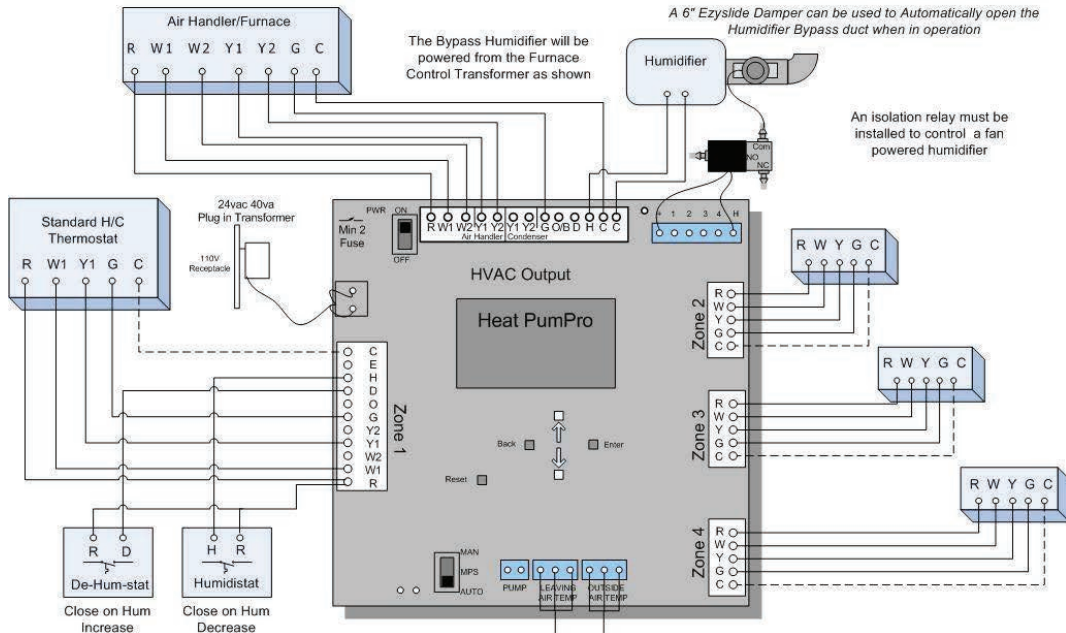

Humidification and Dehumidification from Zone 1 T-Stat

Zone 1 "H" terminal goes to "24" volts during a call for Humidification
 Zone 1 "D" terminal can be configured In the "Set-Up Wizard" as a "24" vac or "0" vac during a Call for Dehumidification

24 v call setting initiates a HeatPumPro Dehumidification function
 0 v call setting initiates an equipment dehumidification function

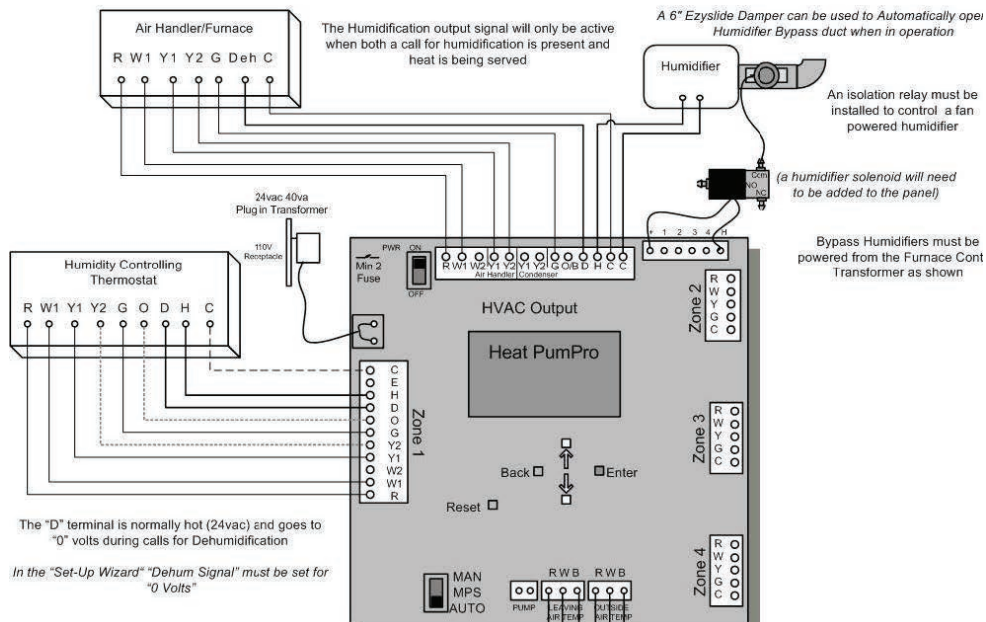

LAT and OAT Sensor Installation

INSTALLATION NOTES

- Both sensors are identical and can be used as either the Leaving Air Temperature (LAT) or Outside Air Temperature (OAT) sensor.
- Both sensors must be connected to the board for proper functionality; non-heat pump applications do not require the OAT sensor to be located outside.
- If additional wire length is required on a sensor, up to 50 ft of 18-3 thermostat wire can be added.
- Keep panel power “off” while connecting sensors to the board.
- The sensors have three conductors, (red, white, black) and must be wired to the appropriate (R, W, B) terminals of the respective sensor terminals.

LAT Sensor Installation

The sensor must be located in the supply trunk, downstream of the heat exchanger and cooling coil and before any trunk dampers.

Do not locate the sensor in an area that is in the direct line of site of the heat exchanger, cooling coil or UV Lights. These locations can cause false readings.

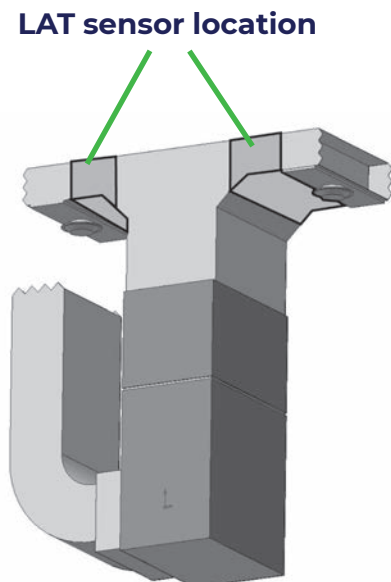

OAT Sensor Installation

1. Choose a location:
 - Out of direct sunlight
 - Above maximum snow level
 - That is accessible should service be required
 - Preferably on the north side of the house
2. Drill a 5/16” access hole through the exterior wall aligned with one of the pre-drilled holes on the back of the enclosure body. If the sensor wire is to run along the outside of the structure, use opening located at the bottom of the enclosure.
3. Mount the sensor enclosure level over the access hole with the sensor opening on the back plate aligned with the 5/16” opening.
4. ALTERNATIVE SENSOR MOUNTING
 - Sensor can be mounted inside the control section of the outdoor condensing unit.
 - Ensure sensor is mounted in a location where its temperature reading will not be influenced by the equipment
 - Route the sensor lead into the sensor enclosure and fasten with the provided wire tie.

An OAT sensor enclosure is provided to protect the outdoor sensor from physical damage as well as snow, ice and solar heat influence.

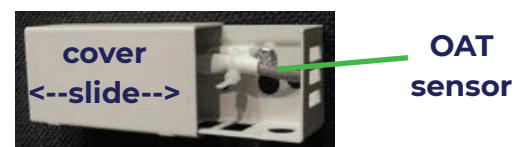

Zone Weight Calculation

The following is an example of “Zone Weight” and “Air Handler Threshold” set-up to demonstrate the functionality behind the settings you choose.

The application below is a two story home being served by four independent zones. The zone weights are determined by simply dividing the number of runs in each zone by the total number of runs in the system. Total zone weight does not need to add up to 100% and may, in fact, be over or under weighted to produce the desired results.

- Zone 1** Living area, 1st floor(5-6” runs/20 = 25%)
- Zone 2** Living area, 1st floor(5-6” runs/20) = 30%
- Zone 3** Master bdrm suite, 2nd floor.....(4-6” runs/20 = 20%)
- Zone 4** Bedrooms, 2nd floor(5-6” runs/20 = 25%)

Total: 20-6” runs

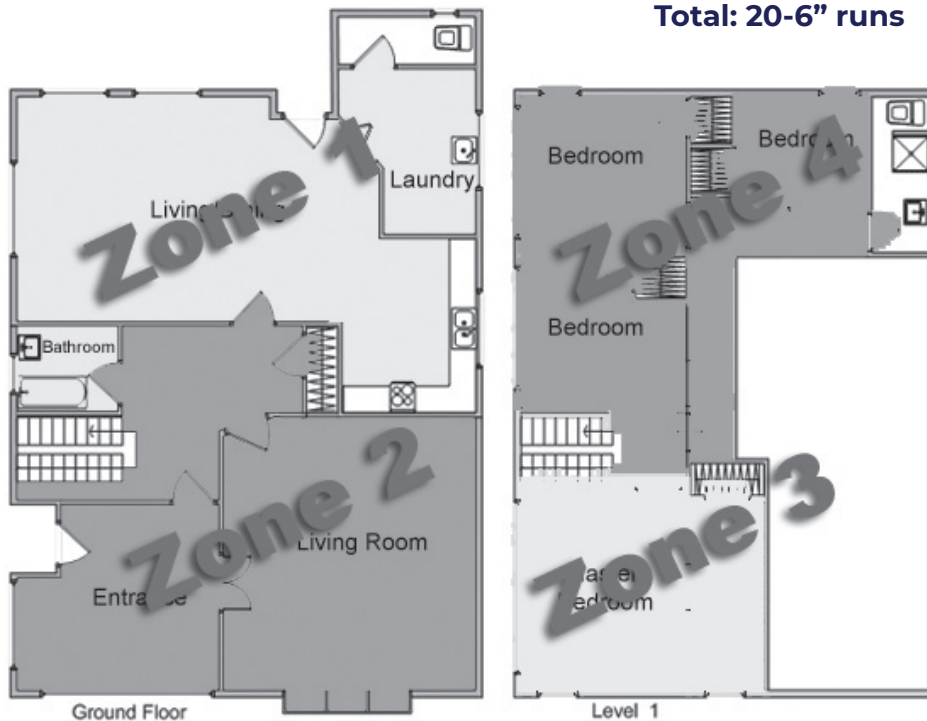

Air Handler Y2 (High Stage) blower and Heating W2 (High Stage) will be engaged any time the accumulated, served zone weight is equal to or greater than the AH Stage Threshold setting in the Set-Up Wizard. There is a 9 minute delay for W2, however there is no delay for Air Handler Y2.

Zone weight settings should provide maximum airflow to zones calling, without creating objectionable air noise at the registers. Since many systems serve a single zone the majority of the time, low stage energy savings will be achieved.

A H Threshold Set-Point	Stage-up occurs when...
100%	All 4 zones call together
80%	Zones 1, 2, and 4 call together
70%	Any 3 zones call together
55%	Zone 2 with either 1 or 4 call together

LAT and OAT Sensors

The HeatPumPro® uses both Leaving Air Temperature (LAT) and Outside Air Temperature (OAT) sensors to protect the HVAC equipment and proactively choose the most appropriate mode of operation.

BOTH SENSORS MUST BE INSTALLED FOR PROPER SYSTEM OPERATION.

The Decision Points in the table below (HST, CST, and AHST) are all adjustable through the Setup Wizard. The contractor is responsible for choosing appropriate staging settings. Multistage thermostats are not required. The HeatPumPro will stage up as required to maintain the amount of cooling or heating that is required by the space based on the Leaving Air Temperature and the Outdoor Air Temperature. It will stage the blower (Multi/Variable Speed Motors) according to the Zone Weight of the ductwork being served.

High and Low limit protection

There are individual high end set-points for Heat Pump heating, auxiliary heat (or FF furnace) and low temperature operating limits for cooling.

The LAT ensures that the HVAC equipment will always be operated inside the OEM specifications. The LAT functions in a staged-manner: As soon as the LAT exceeds the operative limit, the equipment is staged down. If the LAT stays outside acceptable limits for three (3) minutes, then it will cycle off the equipment, leaving only the fan running.

Proactive Staging

The HeatPumPro can handle up to four stages of heating (two-stage heat pump with two stages of electric heat strips or two stages of gas furnace operation). It handles two stages of cooling. The HeatPumPro manages all staging with single stage inputs from all thermostats.

Staging is managed by continually comparing the Leaving Air Temperature to field adjustable heating and cooling thresholds. If the system is not maintaining the appropriate temperature then it will automatically stage up. If it starts to move to the extremes then it will stage down. The table below outlines how the system stages.

HVAC Equipment	Decision Point	Function
Heat Pump Heating	Heat stage threshold (HST) at or above 30°F OAT	Minimum acceptable temperature in the plenum. If the system cannot maintain HST then it will automatically stage up. Note: If the OAT drops below 30°F, the HST rises 1/2 °F for every 1°F below 30°F. So the system will stage more aggressively on colder days.
Fossil Fuel Furnace Auxiliary Heat Strips Multi/Variable Speed Blowers	Air handler staging threshold (AHST)	For auxiliary heat or furnace operations, the system stages up and down based upon the AHST. If the system is serving more zone weight than the AHST it will stage up. If it is serving less than AHST then it will stage down. Airflow with multi/variable speed systems is controlled in the same manner.
Heat Pump A/C Cooling	Cool stage threshold (CST)	Maximum acceptable temperature in the plenum. If the system cannot maintain CST, then it will stage up to high stage automatically.

Pump Operation

Air Pump Operation

Pump will start and control up to 35 actuators any time there is a call for heating, cooling, or fan operation. The pump will continue to run for two minutes plus the “Secondary Purge Time” delay. This allows for all dampers to open to provide a soft start. Pump is designed for continuous operation.

Manual Pump Switch (MPS™)

The Manual Pump Switch (MPS) (pictured here) is provided to test the damper system and to bypass the zoning system in case of a board emergency. This switch will start the pump manually and with the “Power” switch in the OFF position, all the zone dampers will open. This will aid in troubleshooting by allowing the operation of the HVAC system independent of the Arzel® panel, if you suspect a PC board failure.

You can bypass the zoning system by following these steps

1. Turn the Arzel power switch off. You must keep this switch in Off position to block ALL zone thermostats from calling for service and placing all the zone dampers in the normally open position.
2. Disconnect the wires from any one zone thermostat terminal and connect them to the HVAC Output terminals.
3. Turn the MPS switch to manual position.

The HVAC equipment will now be controlled by the one thermostat connected to the Output terminals. The pump will run continuously, holding ALL the zone dampers open.

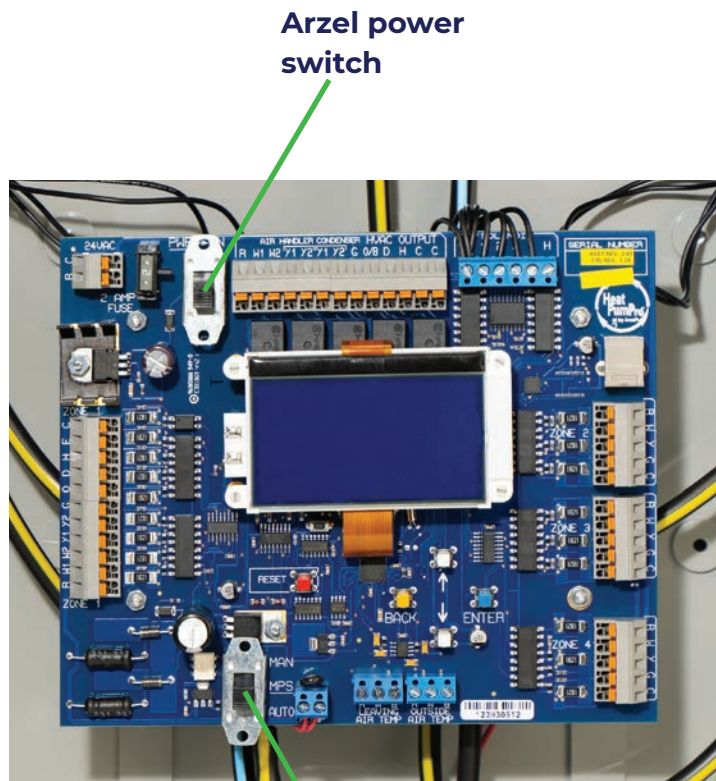

Arzel power switch

Manual pump switch (MPS)

LCD Display Description

Using the LCD Screen

The Liquid Crystal Display (LCD) on the HeatPumPro® is your portal to customizing your zoning installations. The set-up options allow you to design the control sequence in the best interest of your customer, balancing energy usage with comfort delivery while maintaining safe equipment operation. These options can give energy cost priority over comfort, maximum air delivery over noise suppression or fossil fuel priority over heat pump operation. To access the Set-Up Wizard screen, push the red “Reset” button just beneath the LCD, then press the blue “Enter” button.

Operating software version



Press the blue “Enter” button on the circuit board to access the setup wizard.

Viewing System Operations

Once the operating parameters are set in the Set-Up Wizard, the LCD display will default to the “Main Operations” screen shown below.

The image shows the 'Main Operations' screen on the LCD. It displays various system parameters and status indicators. Green lines with labels point to specific parts of the screen:

- Outputs to condenser**: Points to the 'CON' column header.
- Outputs to air handler**: Points to the 'A H' column header.
- Energized output(s) to equipment**: Points to the 'W1 W2 Y1 Y2 Y1 Y2 G O D' row.
- Outdoor ambient temperature**: Points to the 'OAT 65' value.
- Zone(s) being served**: Points to the '1 3' value under 'ZONES'.
- Sum of zone weight(s) for served zones**: Points to the 'WT% 70' value.
- Compressor stages in a 4-minute timed off cycle**: Points to the 'COMPLOCK 12' value.
- Time remaining for the post purge cycles**: Points to the 'PURGE TIME -- : --' value.
- Leaving air temperature in supply duct**: Points to the 'LAT 72' value.

The screen also shows 'BLUE BTN : NXT SCR' at the bottom.

Illegal Calls and Other Messages

The HeatPumPro® has the ability to detect input signals from zone thermostats that do not make sense and provide a visual “ILL” (illegal) call indicator on the LCD screen. By pushing the blue “Enter” button on the board, you can see what each zone is calling for and if that signal falls into the illegal category. Pushing the blue “Enter” button past the last zone will show you any “Messages” regarding staging occurrences, Balance Point status and LAT limit functions.

Status Message Menu

- **Below Balance Point** - OAT is below the set “Balance Point”, back-up heat will be utilized
- **Capacity Stage-Up** - Board logic has staged up to the next level of capacity
- **Resistance Lockout OAT** - OAT is above the “Aux Lock” temperature setting, Aux Heat is locked out
- **LAT Stage Down** - LAT above “HP LAT Htg Limit”, staged down one level of capacity
- **Dehum Off Cycle** - Dehumidification cycle is in a “timed off period” to prevent overcooling of space

Sequence of Operation

On a Call for Heat

1. The thermostat will send the appropriate signal to the circuit board.
 - Zone 1 = Y1, G or W
 - Zone 2, 3, 4 = W
2. The HeatPumPro® will consider the Balance Point (BP) setting if auxiliary heat is fossil fuel or Aux Balance Point is set to True.
 - If the OAT is above the BP setting the Y1 and G signal will be sent to the air handler and a Y1 signal will be sent to the condenser (O/B will also be energized if set for Rev Valve Energized in Htg mode).
 - If the OAT is below the BP setting then W1 will be energized to initiate back-up fuel operation, W2 will be controlled by the zone weight logic.
 - If the BP setting is set for "Lock in Backup Heat" then all heat calls will be served with a W1 output (fossil fuel) regardless of the OAT. W2 will be controlled by the zone weight logic.
3. The control panel pump will start, and the non-calling zones' solenoids will energize to close dampers.
4. The LAT sensor will start to monitor the air in the supply plenum. The sensor will be looking for the temperature set for the "Heat Stage Threshold" in the Setup Wizard plus an OAT adjustment. The threshold temperature will raise 1° for every 2° drop in OAT below 30 °F.
 - Ex. HST = 100 °F in Set-up Wizard:
30 °F OAT → 100 °F LAT threshold
20 °F OAT → 105 °F LAT threshold
5. The LAT sensor will continue to monitor the supply air temperature. If the temperature levels off below the heat stage threshold setting, the HeatPumPro® will output for the next stage of heat every three minutes.
 - Y1 = stage 1 heat
 - Y2 = stage 2 heat
 - W1 = stage 3 heat
 - W2 = stage 4 heat
6. The LAT sensor will continue to monitor the supply air temperature and continue to stage up until all stages of heat are on or the heat stage threshold is met. With an all electric system the HeatPumPro® will stage the electric heat on with the heat pump running. With fossil fuel back-up if the heat stage threshold is not met within 6 minutes the heat pump will be turned off and the panel will start a W1 output.
7. If the temperature in the supply plenum reaches the auxiliary high limit it will begin to stage down the equipment while still maintaining a temperature above the Heat Stage Threshold.
8. When the zone is satisfied the equipment will turn off, the zone will stay open for two minutes and then run the pump for the time set in the secondary purge time in the Set-Up Wizard to open the rest of the dampers and allow for a soft start on the next cycle.

Sequence of Operation

On a Call for Cooling

1. The thermostat will send the appropriate signal to the circuit board: Y1, G, O or Y1, G for zone 1 depending on the thermostat type; Y, G for zones 2, 3, or 4.
2. The pump will start, and will energize the solenoid for any zone that is not calling.
3. The Y1, Y2, G signal will be sent to the air handler if the "Air Handler Stage Threshold%" (AHST) is met. Otherwise, only Y1, G will be sent to the air handler. A Y1 signal will be sent to the condenser, and an O/B will be sent if set for Rev Valve Energized in Cooling.
4. The LAT sensor will monitor the supply air temperature in the plenum and look for the temperature set in the cool stage threshold in the Set-Up Wizard. If the LAT sensor senses a continuous decrease in temperature, it will leave the system in first stage cooling.
5. If the supply temperature (LAT) is below the cool stage threshold, it will send a Y2 signal to the condenser after 3 minutes.
6. If the supply air temperature reaches the cooling low limit setting the signal to Y2 will be removed.
7. When the zone is satisfied the equipment will turn off, the zone will stay open for 30 seconds and run the pump for the time set in the secondary purge time in the Setup Wizard to open the rest of the dampers and allow for a soft start on the next cycle.

Setup Wizard

To access the Set-Up Wizard for the HeatPumPro® confirm that the Power Switch is “ON”, then press the red “RESET” button and immediately press the blue “ENTER” button while the start up screen is active. Use the white UP and DOWN buttons to change Options within each Category. Below are the setup categories in the order they appear in the software. The Setup Worksheet in the back of the manual can be used to document your settings.

All settings are held in memory even when power is interrupted. To view options or make changes after initial setup, simply press the red “RESET” button and proceed through the setup categories, making any necessary changes, using the white “UP” and “DOWN” buttons.

Parameter	Description	Options	Factory Default
Show Temperature In	Determines the temperature display scale on the HeatPumPro®	<ul style="list-style-type: none"> ● Fahrenheit ● Centigrade 	Fahrenheit
Priority	<p>Allows specified mode to interrupt active cycle. Priority options include: Automatic, Heating, Cooling, or Zone Weight Priority.</p> <p>Automatic Priority: Auto priority will allow the first call (either heating or cooling) to establish the priority sequence for this cycle. A heating or cooling call will always override fan-only operation. Any zone can initiate constant fan if no other zone has a demand for either heating or cooling.</p> <p>Zone Weight Priority: Zone Weight priority allows the call in the largest weighted zone(s) to have priority over any opposing calls in the smaller zones. The board continues that call until the largest weight zone is satisfied or the opposing call becomes the larger zone.</p> <p>Heating Priority: Heating priority allows heating to have priority over cooling. Any zone calling for heating will be served immediately; if a cooling cycle is in process it will be terminated. The mode being served will be limited to a 20-minute cycle.</p> <p>Cooling Priority: Cooling priority allows cooling to have priority over heating. Any zone calling for cooling will be served immediately if no other zone wants cooling. Any zone can have constant fan, if no other zone wants cooling or heating.</p> <p>Note: In Heating, Cooling and Automatic Priority the board will serve the priority caller for 20 minutes then the opposing call for 20 minutes and rotate until all calls are satisfied.</p>	<ul style="list-style-type: none"> ● Automatic ● Zone Weight ● Heating ● Cooling 	

Setup Wizard

Parameter	Description	Options	Factory Default
Zone 1 Stat Type	Type of T-stat used on Zone 1 Enter the type of thermostat you are connecting to Zone 1 of the HeatPumPro panel.	<ul style="list-style-type: none"> ● Heat Pump ● Heating/Cooling 	Heating/ Cooling
Zone 1 Weight %	Zone 1 relative weight Enter the percentage of available ductwork to system capacity in each zone. Ex) Calculate nominal CFM for the zone and divide by total system capacity. This can also be used to set priority to a specific zone by giving it a larger weight. Sum of zones does not need to equal 100%.	10-90%, 5%	50%
Zone 2 Weight %	Zone 2 relative weight	10-90%, 5%	50%
Zone 3 Weight %	Zone 3 relative weight	10-90%, 5%	50%
Zone 4 Weight %	Zone 4 relative weight	10-90%, 5%	50%
AH Stage-up Threshold	Air handler Stage-up threshold, Y2 output to Air Handler or W2 to FF Furnace engaged when threshold % is reached. Set the percentage of ductwork you would want to be open before the HeatPumPro® panel will send a Y2 signal to the air handler to increase capacity or W2 signal to furnace to increase output capacity.	30-100%, 5%	50%
Heat Stage Threshold	Min leaving air temp (LAT) required for comfort at 30 °F outside air temperature (OAT). This set-point adjusts by 1 °F for every 2 °F change in OAT. Sets the minimum supply air temp in the heating mode. At the factory default the HeatPumPro® will maintain a 88° F supply air temp at 30° F outdoor temperature. The supply air temperature will raise or lower 1 °F for every 2 °F change in outdoor temperature.	80-130 °F, 1 degree increments	88 °F
Cool Stage Threshold	Max cooling supply air temp, Y2 is energized if this LAT is not reached with Y1 output. Sets the maximum supply air temperature allowable before bringing on second stage cooling. Does not reset with OAT.	20-60 °F, 1 degree increments	55 °F

Setup Wizard

Parameter	Description	Options	Factory Default
Balance Point OAT Set to "Lock in Back-up" for non-heat pump applications.	Heat pump operates above BP set point and FF furnace operates below set-point. Set the outdoor temperature at which you want to lock the heat pump out and have the fossil fuel back up to take over on a call for heat. This setting is overridden by the "Heat Stage Threshold" function.	0-50 °F, 1 degree increments or "Lock in Back-up Heat" for non-Heat Pump applications	Lock in Back-up Heat
Resistance Lockout OAT	Aux Heat (Elect Resistance) will be locked out when OAT exceeds this setting. Set the outdoor temperature at which you want to lock out the electric resistance heat.	0-40 degrees F, or "Lock in Aux" to allow elect aux heat staging regardless of OAT	30 °F
HP LAT High Limit	High limit of heat pump leaving air temperature. Set the maximum allowable supply air temperature in heat pump mode.	100-125 °F, in 1-degree F steps	120 °F
AUX.LAT High Limit	Aux "W" output leaving air temp high limit. Set the maximum allowable supply air temperature in fossil fuel or electric resistance heat operation.	130-180 °F, in 1-degree F steps	140 °F
Cooling LAT Low Limit	Cooling leaving air temp low limit. Set the minimum supply air temperature in the cooling cycle to prevent the coil from freezing.	34-46 °F, in 1-degree F steps	42 °F
Type of back-up	Specify type of Aux "Back-Up" heat. Select the type of heat that will be initiated when the heat pump can no longer maintain the setting of the heat stage threshold.	<ul style="list-style-type: none"> ● Electric ● Fossil Fuel 	Fossil Fuel
Back-up controls fan	G output for fossil fuel heat operation True="W" False="W", "G." Select true if the back-up heat source controls the fan internally or false if the HeatPumPro needs to initiate the fan.	<ul style="list-style-type: none"> ● True ● False 	True
Dehum Caller Voltage	Required voltage to energize a dehumidification call. Note: Leave setting at 24v when not used. Set to the dehumidification control voltage output on the dehumidistat control, Y.	<ul style="list-style-type: none"> ● 0 Volt ● 24 Volt 	24 Volt

Setup Wizard

Parameter	Description	Options	Factory Default
Secondary Purge Time	<p>End-of-cycle purge time to diffuse residual heating or cooling.</p> <p>Set the amount of time in seconds to run the pump after a cycle to open all the dampers. Typically 5 seconds per damper.</p>	0-180 seconds, 10 sec increments	60 seconds
Dehumid Cycle Time	<p>Dehumidification "On Cycle" time limit to prevent over-cooling of space once cooling set-points are reached (off cycle is fixed at 10 min).</p> <p>Set the maximum "ON" time for the dehumidification cycle to prevent over cooling of the space. The "OFF" cycle is set at a fixed time of 10 minutes.</p>	5-15 minutes, 5 minute increments	10 minutes
CLG Low Ambient Lock	<p>Minimum OAT that mechanical cooling is allowed to operate (locks out CON Y output).</p> <p>Set the outdoor temperature at which the cooling will no longer come on.</p>	20-60, 1 degree F increments	50 °F
Rev Valve Energized	<p>Heat pump reversing valve energized in heating or cooling (Zone 1 HP stat always calls "O" for clg call").</p> <p>Set the mode in which the reversing valve is energized.</p> <p>If the heat pump thermostat has a setting for reversing valve in the configuration mode, set the thermostat to energize the reversing valve in cooling.</p>	<ul style="list-style-type: none"> ● Cooling ● Heating 	Cooling
Use Bal Pt for Elec	<p>Allow Balance Point to be used on all electric system. True heat pump will shut down when ODT is below Balance Point setting.</p>	<ul style="list-style-type: none"> ● True ● False 	False
Demo Mode Enabled	<p>Demo mode speeds up all timing sequences by a factor of 12. Used for demonstrations and for initial system commissioning.</p>	<ul style="list-style-type: none"> ● True ● False 	False

Suggested Settings

Settings in **bold** must be set to this value. Other settings are suggested. N/A = Not applicable for this application.

Single Stage Fossil Fuel with A/C

F or C..... Fahrenheit
 Priority..... Automatic
Zone 1 Stat TypeHeat/Cool
 Zone 1 Weight..... N/A
 Zone 2 Weight..... N/A
 Zone 3 Weight..... N/A
 Zone 4 Weight..... N/A
 AH Stage Threshold..... N/A
 Heat Stage N/A
 Cooling Stage N/A
Balance Point.....Lock-in
 Resistance Lockout..... N/A
 HP High Limit..... N/A
 Aux High Limit 140
 Cooling Low Limit..... 42
Backup Fuel Type.....Fossil Fuel
 Backup Control Fan..... TRUE
 Dehum Voltage 24
 Secondary Purge..... 60
 Dehum Cycle Time..... set as needed
 CON Lockout Temp 50
 Rev Valve Energized..... N/A
Balance Point for Elec.....FALSE
Demo ModeFALSE

Multi-Stage Fossil Fuel with A/C

F or C..... Fahrenheit
 Priority..... Automatic
Zone 1 Stat TypeHeat/Cool
 Zone 1 Weight..... set as needed
 Zone 2 Weight..... set as needed
 Zone 3 Weight..... set as needed
 Zone 4 Weight..... set as needed
 AH Stage Threshold..... set as needed
 Heat Stage N/A
 Cooling Stage 55
Balance Point.....Lock-in
 Resistance Lockout..... N/A
 HP High Limit N/A
 Aux High Limit 140
 Cooling Low Limit..... 42
Backup Fuel Type.....Fossil Fuel
 Backup Control Fan..... TRUE
 Dehum Voltage 24
 Secondary Purge..... 60
 Dehum Cycle Time..... set as needed
 CON Lockout Temp 50
 Rev Valve Energized..... N/A
Balance Point for Elec.....FALSE
Demo ModeFALSE

Multi-Stage Dual Fuel

F or C..... Fahrenheit
 Priority..... Automatic
 Zone 1 Stat Type HP or Heat/Cool
 Zone 1 Weight..... set as needed
 Zone 2 Weight..... set as needed
 Zone 3 Weight..... set as needed
 Zone 4 Weight..... set as needed
 AH Stage Threshold..... set as needed
 Heat Stage 88
 Cooling Stage 55
 Balance Point..... 30
 Resistance Lockout..... N/A
 HP High Limit..... 120
 Aux High Limit 140
 Cooling Low Limit..... 42
Backup Fuel Type.....Fossil Fuel
 Backup Control Fan..... TRUE
 Dehum Voltage 24
 Secondary Purge..... 60
 Dehum Cycle Time..... set as needed
 CON Lockout Temp 50
 Rev Valve Energized..... set as needed
Balance Point for Elec.....FALSE
Demo ModeFALSE

Single-Stage Heat Pump with Electric Backup

F or C..... Fahrenheit
 Priority..... Automatic
 Zone 1 Stat Type HP or Heat/Cool
 Zone 1 Weight..... N/A
 Zone 2 Weight..... N/A
 Zone 3 Weight..... N/A
 Zone 4 Weight..... N/A
 AH Stage Threshold..... N/A
 Heat Stage 88
 Cooling Stage N/A
 Balance Point..... N/A
 Resistance Lockout..... Lock In
 HP High Limit..... 120
 Aux High Limit 140
 Cooling Low Limit..... 42
Backup Fuel Type.....Electric
 Backup Control Fan..... FALSE
 Dehum Voltage 24
 Secondary Purge..... 60
 Dehum Cycle Time..... set as needed
 CON Lockout Temp 50
 Rev Valve Energized..... set as needed
 Balance Point for Elec..... set as needed
Demo ModeFALSE

Suggested Settings

Settings in **bold** must be set to this value. Other settings are suggested. N/A = Not applicable for this application.

Multi-Stage Heat Pump with Electric Backup

F or C.....	Fahrenheit
Priority.....	Automatic
Zone 1 Stat Type	HP or Heat/Cool
Zone 1 Weight.....	set as needed
Zone 2 Weight.....	set as needed
Zone 3 Weight.....	set as needed
Zone 4 Weight.....	set as needed
AH Stage Threshold.....	set as needed
Heat Stage	88
Cooling Stage	55
Balance Point.....	N/A
Resistance Lockout.....	Lock In
HP High Limit.....	120
Aux High Limit.....	140
Cooling Low Limit.....	42
Backup Fuel Type.....	Electric
Backup Control Fan.....	FALSE
Dehum Voltage.....	24
Secondary Purge.....	60
Dehum Cycle Time.....	set as needed
CON Lockout Temp	50
Rev Valve Energized.....	set as needed
Balance Point for Elec.....	set as needed
Demo Mode	FALSE

Inverter with Electric Backup

F or C.....	Fahrenheit
Priority.....	Automatic
Zone 1 Stat Type	HP or Heat/Cool
Zone 1 Weight.....	set as needed
Zone 2 Weight.....	set as needed
Zone 3 Weight.....	set as needed
Zone 4 Weight.....	set as needed
AH Stage Threshold.....	set as needed
Heat Stage	80
Cooling Stage	55
Balance Point.....	30
Resistance Lockout.....	25
HP High Limit.....	120
Aux High Limit.....	140
Cooling Low Limit.....	42
Backup Fuel Type.....	Electric
Backup Control Fan.....	FALSE
Dehum Voltage.....	24
Secondary Purge.....	0
Dehum Cycle Time.....	set as needed
CON Lockout Temp	50
Rev Valve Energized.....	set as needed
Balance Point for Elec.....	set as needed
Demo Mode	FALSE

Dual Fuel with Inverter Heat Pump

F or C.....	Fahrenheit
Priority.....	Automatic
Zone 1 Stat Type	HP or Heat/Cool
Zone 1 Weight.....	set as needed
Zone 2 Weight.....	set as needed
Zone 3 Weight.....	set as needed
Zone 4 Weight.....	set as needed
AH Stage Threshold.....	set as needed
Heat Stage	80
Cooling Stage	55
Balance Point.....	set as required*
Resistance Lockout	equal to balance point*
HP High Limit.....	120
Aux High Limit.....	140
Cooling Low Limit.....	42
Backup Fuel Type.....	Electric*
Backup Control Fan.....	TRUE
Dehum Voltage.....	24
Secondary Purge.....	0
Dehum Cycle Time.....	set as needed
CON Lockout Temp	50
Rev Valve Energized.....	set as needed
Balance Point for Elec.....	TRUE*
Demo Mode	FALSE

* NOTES

Inverter heat pumps are designed to run for an extended period and often lower supply temperatures. The HeatPumPro upstages to fossil fuel after a 6-minute run cycle if the "Heat Stage Threshold" is not met. Non-standard settings are needed to overcome this. The HeatPumPro needs to think there is an electric heater providing an OAT lockout on W1 while still changing from heat pump to fossil fuel when meeting balance point where the heat pump won't maintain.

Balance Point OAT and Resistance Lockout must be set to the same temperature, with Backup Fuel Type "Electric" and Balance Point for Elec "TRUE." This will keep the gas furnace from engaging during extended run cycles but also provide an ODT changeover from heat pump to fossil fuel.

System Commissioning

To ensure the Arzel® HeatPumPro® zoning system operates properly after completing all installation and system configuration steps, please follow the procedures below for commissioning the system.

Damper Verification

1. Set all thermostats to the OFF mode and all thermostat fan switches to AUTO.
 2. Turn the HVAC system and the HeatPumPro® system PWR switches to ON.
 3. Verify proper LAT and OAT temperature readings on the display screen.
 4. Turn the Zone 1 thermostat fan switch ON. The fan in the HVAC system will turn on. Check the airflow at all registers to determine that only Zone 1 dampers are open and all other dampers are closed.
 5. Follow the above procedure for all other zones.
2. Remove the leaving air temperature (LAT) sensor from the supply ductwork.
 3. Initiate a call for heat on Zone 1, a Y1 and G signal to the air handler and a Y1 signal to the condenser will appear on the display screen.
 4. Initiate a call in a second zone that will raise the zone weight threshold above its setting. A Y2 signal to the air handler will appear on the display screen and blower will ramp up to second stage.
 5. Allow the unit to run in heating mode, a Y2 signal will appear and the second stage on the condenser will energize.
 6. Allow the unit to continue to operate and a W1 signal will appear on the display screen and energize the first stage back-up heat.
 7. Allow the unit to continue to operate and a W2 signal will appear on the display screen and energize the second stage back-up heat.
 8. Turn thermostats off and allow system to cycle off, do not reinstall LAT sensor at this time.
 9. Reset the demo mode to FALSE in the Set-up Wizard.

Bypass Adjustment and Checkout

1. Set smallest zone to appropriate zone weight threshold.
2. Initiate highest expected blower operation heating or cooling call.
3. Adjust the bypass closed and have the customer determine if the air delivery noise is objectionable. The customer must be informed that elevated air delivered into the smallest zone is critical to effective system operation when a single zone call.
4. Adjust the bypass in small increments until the objectionable noise is eliminated. (Bypass is only done to eliminate objectionable air noise; consult the homeowner to determine their needs.)
5. Initiate call in other small zone or zones until AH stage threshold upstages equipment and re-verify with equipment blower operating at highest capacity.

Air Handler Stage Threshold and Heat Threshold Checkout

1. Set all thermostats to the OFF position. Set the demo mode to TRUE in the Setup Wizard.

Note: With electric resistance backup heat the outdoor air temperature must be below the temperature set for the resistance lockout temperature.

Cooling Stage Threshold Checkout

1. With the LAT sensor removed from the ductwork initiate a call for cooling from any zone.
2. The Y1, G and O signal will appear on the display screen and send a first stage cooling signal to the air handler and the condenser.
3. Allow the unit to continue to operate. A Y2 signal will appear on the display screen and send a second stage cooling signal to the condenser.

System Commissioning

- Turn the thermostats to OFF and install Leaving Air Temperature sensor into the supply duct.
- Reset the demo mode to FALSE in the Set-Up Wizard.

Balance Point Checkout (Fossil Fuel Backup)

- Raise the balance point temperature setting above the outdoor air temperature or submerge the outdoor air temperature sensor in a cup of ice to lower the reading.
- Initiate a call for heat in any zone.
- The W1 signal will appear on the display screen and initiate a call for the fossil fuel heating equipment.
- Turn zone thermostat off and allow the heating equipment to cycle off.

Customer Orientation

- In an effort to eliminate end user misunderstandings and potential call-backs, review the Setup Wizard parameters and explain how the system should be expected to function.
- Go over thermostat locations and functions and advise on the most energy saving set-back settings (Setting back all zones during their unoccupied period will provide the best savings.)
- If Zone One thermostat is equipped with an "Emerg Heat" mode explain when and how to use it and the expected equipment operation in the Emerg Ht mode.

Remote Emergency Heat Switch

If an Emergency Heat Switch is desired and the Zone 1 thermostat is not a heat pump model or there are not enough conductors to provide an "E" circuit, then a remote "EM HT" switch can easily be wired to the board.

Simply wire a normally open switch across the Zone 1 "R" and "E" terminals and you can engage the Emerg Ht mode by closing the switch. This will serve all heat calls with the aux heat source.

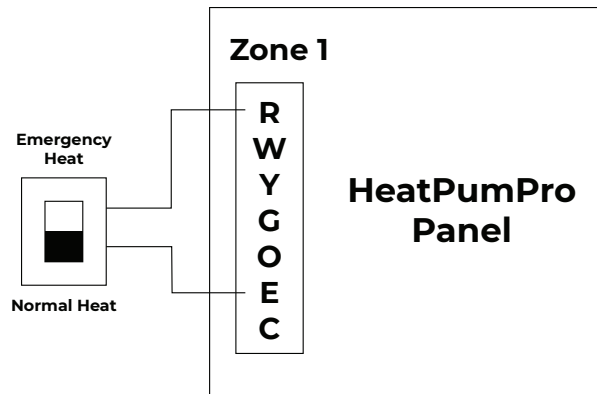

Zoning System Layout

Zone	Tube Color	Total # Dampers	T-Stat Location
1			
2			
3			
4			

Setup Worksheet

Fill in the right-hand column with the Set-Up Wizard settings that you use when programming the panel. Record the setup date. If any settings change, record those changes and the date they were made.

Settings

Function	Options	Initial Setup		Adjusted	
		Setting	Date	Setting	Date
Temperature Display	F/C				
Mode Priority	Automatic, Cooling, Heating, Zone Weight				
Zone 1 T-Stat	Heat Pump or Heating/Cooling				
Zone 1 Weight	Zone 1: 10%-90%				
Zone 2 Weight	Zone 2: 10%-90%				
Zone 3 Weight	Zone 3: 10%-90%				
Zone 4 Weight	Zone 4: 10%-90%				
Air Handler Stage Threshold	30% - 100%				
Heat Stage Threshold	Enter Temp: 80 - 130				
Cool Stage Threshold	Enter Temp: 20 - 60				
Balance Point OAT	Enter Temp: 0 - 50 of backup heat				
Resistance Lockout OAT	Enter Temp: 0 - 40, or Lock-In				
Heat Pump LAT High Limit	Enter Temp: 100 - 125				
Aux LAT High Temp	Enter Temp: 130 - 180				
Cooling LAT Low Temp	Enter Temp: 34 - 46				
Type of Backup	Electric or Fossil Fuel				
Backup Controls Fan	True or False				
Dehumidifier Call Voltage	0 VAC or 24 VAC				
Secondary Purge Time	Enter seconds: 0 - 180				
Dehumidification Cycle Time	Enter minutes: 5, 10, or 15				
Cooling Low Ambient Lockout	Enter Temp: 20 - 60				
Reversing Valve Energized	Cooling or Heating				
Use Balance Point for Electric	True or False				
Demo Mode Enabled	True or False				

Bypass Sizing Charts

Branch Dampers

Smallest Zone CFM	Blower Tonnage						Round Bypass Size
	2	2.5	3	3.5	4	5	
100	*	8	8	10	10	12	
200	*	*	8	8	10	10	
300	N/A	N/A	*	*	8	10	
400	N/A	N/A	N/A	*	*	8	
500	N/A	N/A	N/A	N/A	*	8	
600	N/A	N/A	N/A	N/A	N/A	*	
700	No Bypass Required						
800	No Bypass Required						
900	No Bypass Required						
1000	No Bypass Required						

Trunk Dampers

Smallest Zone CFM	Blower Tonnage						Round Bypass Size
	2	2.5	3	3.5	4	5	
100	8	10	10	12	12	14	
200	8	10	10	12	12	14	
300	*	*	8	10	10	12	
400	N/A	*	*	8	10	12	
500	N/A	N/A	*	*	8	10	
600	N/A	N/A	N/A	*	*	10	
700	N/A	N/A	N/A	N/A	*	8	
800	N/A	N/A	N/A	N/A	N/A	*	
900	N/A	N/A	N/A	N/A	N/A	*	
1000	No Bypass Required						

Other Bypass Sizing Considerations

Flex Duct

Down-size the bypass by one size due to increased friction loss inherent in flex duct.

Distant Zones

Duct length greater than 200 ft. may require a one size decrease due to increased friction loss.

Close Zones

Duct length less than 50 ft. may require a one size increase.

Special Purpose Zones

Usage patterns may require an increase in bypass size.

- Calculate bypass from low stage CFM tonnage when combining 2-stage split systems with HeatPumPro or GTPro panels and using zone weight.
- Keep the bypass as small as possible.
- Bypass should be at least 8 ft. from the return drop when possible.

EzySlide Damper Installation

For video demos, visit www.arzelzoning.com.

1. Apply the template with the airflow arrow pointed towards the register.



2. Cut out the triangle. Drill a 3/4-inch hole at each of the 3 corners and connect the holes with your snips.



3. Insert the damper. Hold it in the closed position, and insert the blade at the wide end of the triangle.



4. Twist into position. After the blade is inserted, rotate the damper 90° with the tubing port facing the main duct.



5. Fasten with zip screws. Secure the damper at two opposing corners. Add the other two screws. Tighten all four screws to just seal the gasket.



6. Attach the air line. Cut a 3/4-inch section out of the "homerun tube" for that zone and insert a tee to connect to the damper.



7. Finished! If the tubing looks neat and well organized, the workmanship appears worthy of the investment.



Rectangular EzySlide Install

Cut out a rectangle with the inside dimensions of the gasket. Align the damper blade from corner to corner and slide it into the opening. Turn damper to align with the duct, and fasten with screws.

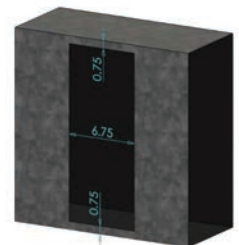

Warranty Information & Procedure

Limited Lifetime Warranty Information can be found at www.arzelzoning.com/warranty

Warranty Information

Limited Lifetime Warranty on Panel & Dampers if warranty information is submitted to Arzel Zoning Technology, Inc. for Limited Lifetime Warranty Coverage within 90 days of installation.

The Panel serial number is required when entering warranty information. This serial number is located on a sticker inside the panel box. See photos below for possible locations.



Warranty Procedure

To receive an RMA, technicians must call while on site (no call-no warranty). Warranties returned to distributors without prior authorization may be denied or subject to 20% processing fee.

1. Call 800-611-8312 while on the jobsite to diagnose failed parts and continue the warranty process.
2. Any diagnosis of failed parts must be verified by Arzel® Technical Support to receive an RMA (Return Material Authorization).
3. All warranty claims must include the serial number of the panel (see image above).
4. Arzel will ship warranty parts directly to licensed contractors via UPS Ground. (Next day air is available at an additional cost.)
5. Arzel Technical Support is available 7 days a week from 8am - 9pm EST.

Scan within 90 days of installation for warranty information.

